

Rexroth Frequency Converter

EFC x610 / VFC x610

Extension Module and Extension Card Module

Mounting Instructions

R912006261
Edition 01

Extension Module Mounting

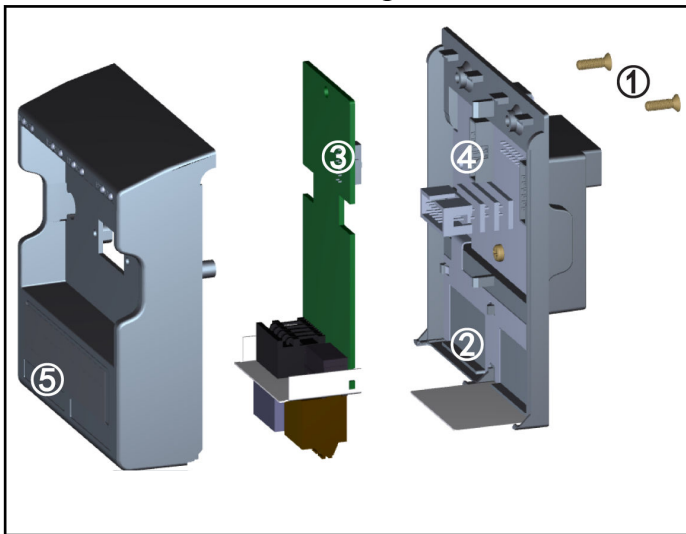

Extension module mounting

1. Remove 2-M3 screws ① on back of the extension card module.
2. Remove the front cover of the extension card module.
3. Insert one extension card into the card slot with the metal plate beside the extension card terminals placed in ②.
4. Push the extension card to achieve a stable connection of connector ③ (on the back side of the extension card) with connector ④ (on the extension card module).
5. Mount the front cover of the extension card module.
6. Tighten 2-M3 screws ① of the extension card module.
7. Attach an appropriate terminal label on the label indentation ⑤ located at the lower section of the front cover. Terminal labels for various extension cards are delivered together with each extension card.

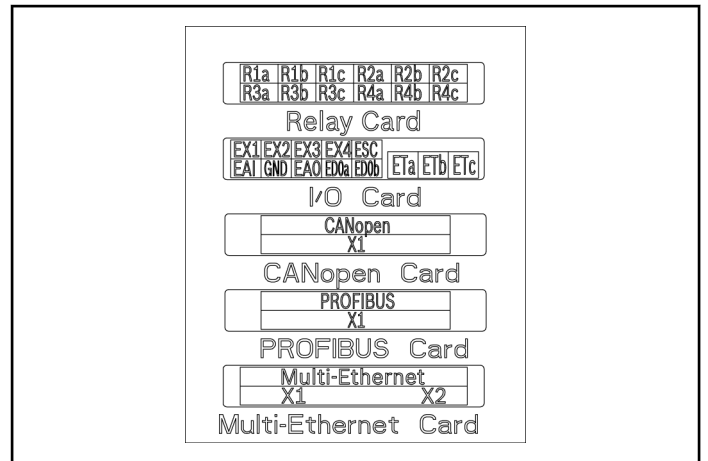

Terminal labels of extension cards



- ▶ Maximum two extension cards can be mounted in one extension card module.
- ▶ Extension cards in the two card slots **CAN-NOT** be the same.
- ▶ **ONLY ONE** type of communication card can be mounted in one extension card module.

Extension Card Module Mounting

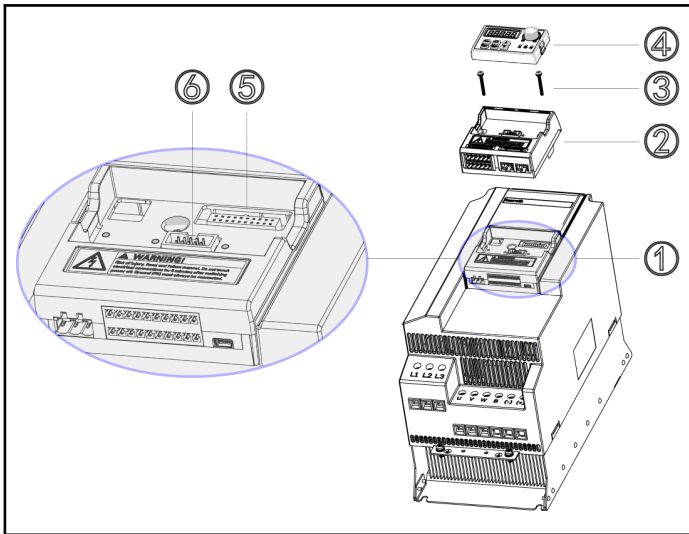

Extension card module mounting

1. Remove operating panel ④ from Control & Terminal module ①.
2. Mount extension card module with extension cards ② into Control & Terminal module ①.
3. Tighten two screws ③ to fix extension card module ② in Control & Terminal module ①.
4. Push operating panel ④ into extension card module ②.



- ⑤: Control & Terminal module connector
 ⑥: Connector for operating panel



Copyright

© Bosch Rexroth (Xi'an) Electric Drives and Controls Co., Ltd. 2015
 This document, as well as the data, specifications and other information set forth in it, are the exclusive property of Bosch Rexroth (Xi'an) Electric Drives and Controls Co., Ltd. It may not be reproduced or given to third parties without its consent.